

Force Briquetting Presses HQ

70-150HQ

Construction features

- Base frame, bearing the control unit's oil tank.
- Pump motor unit positioned under the oil tank
- Press mechanics composed of pre-compaction piston, ejector piston, compaction head, extruder and piston clamp.
- Screw feeder hopper
- Air-oil exchanger
- Ø 1500 mm mini silo with H 1000 mm element complete with level indicators for automatic operation
- Press electric control panel with plc.
- Briquette breaker.

Main characteristics

- Dosing auger for homogeneous product feeding
- Immediate on/off, minimum start times
- High quality components
- 100% designed and produced in Italy
- Minimum wear of the components
- Heavy loads, suitable for continuous operation
- Automatic operation

Technical specifications

Models	Main motor	Auxiliary motors	Operating pressure	Hourly production with wood chips and sawdust	Briquette Ø	Briquette Length	Weight	Dimensions in millimetres		
Code	kW	kW	Bar	Kg/h	mm	mm	kg	A	B	H
M0109010001	15	1,5+1,5	170 - 200	120 - 150	70	30 - 300	1650	2180	1700	1720

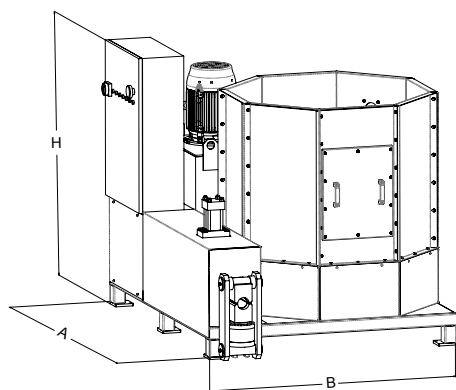

120-150 kg/h



Ø 70 mm



Costruzioni Nazzareno S.r.l.

Via delle Industrie, 17 (Z.I. Vacil)
31030, Breda di Piave (TV) ITALY
Tel: +39 0422 600592
Fax: +39 0422 607119
info@nazzareno.it

Force Briquetting Presses HQ

80-250HQ

Construction features

- Base frame, bearing the control unit's oil tank.
- Pump motor unit positioned under the oil tank
- Press mechanics composed of pre-compaction piston, ejector piston, compaction head, extruder and piston clamp.
- Screw feeder hopper
- Air-oil exchanger
- Ø 1500 mm mini silo with H 1000 mm element complete with level indicators for automatic operation
- Press electric control panel with plc.
- Briquette breaker.

Main characteristics

- Dosing auger for homogeneous product feeding
- Immediate on/off, minimum start times
- High quality components
- 100% designed and produced in Italy
- Minimum wear of the components
- Heavy loads, suitable for continuous operation
- Automatic operation

Technical specifications

Models	Main motor	Auxiliary motors	Operating pressure	Hourly production with wood chips and sawdust	Briquette Ø	Briquette Length	Weight	Dimensions in millimetres		
Code	kW	kW	Bar	Kg/h	mm	mm	kg	A	B	H
M0120010001	22	1,5+1,5	170 - 200	200 - 250	80	30 - 300	1780	2180	1700	1920

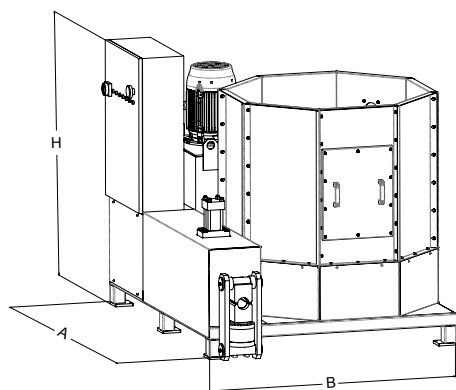

200-250 kg/h



Ø 80 mm



Costruzioni Nazzareno S.r.l.

Via delle Industrie, 17 (Z.I. Vacil)
31030, Breda di Piave (TV) ITALY
Tel: +39 0422 600592
Fax: +39 0422 607119
info@nazzareno.it